

Here are the tools  
you'll need to become an  
InstallationMaster™

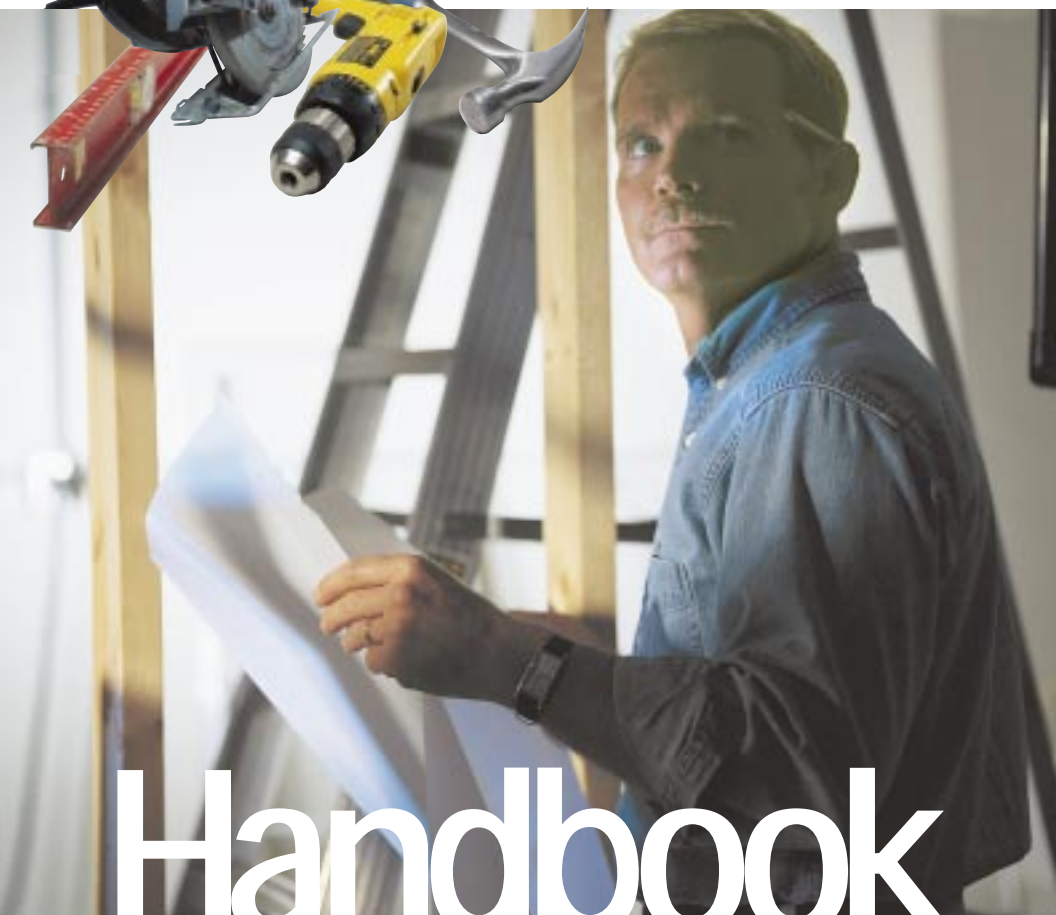

# Handbook

Residential & Light Commercial Window and Door Installation Training and Certification Program

INSTA//ATION™  
*Masters*

Level RLC-1

# Important Information about InstallationMasters™

This handbook is provided to supply you with the registration requirements and content of the InstallationMasters™ Training and Certification Program. Inside you will find an overview of the program, what to expect when you attend, and important information about eligibility and registration.

After you are registered, you will receive an InstallationMasters™ Training Manual. Developed as an industry-approved installation training guide for Residential/Light Commercial Windows and Doors, the InstallationMasters™ Training Manual will take you through your training and prepare you for your test at the end of the course.

In-depth installation training, registration, and practical tools to take home - that is only the beginning of what you can get with the InstallationMasters™ Training and Certification Program. So turn the page, check-it out, and sign-up today.

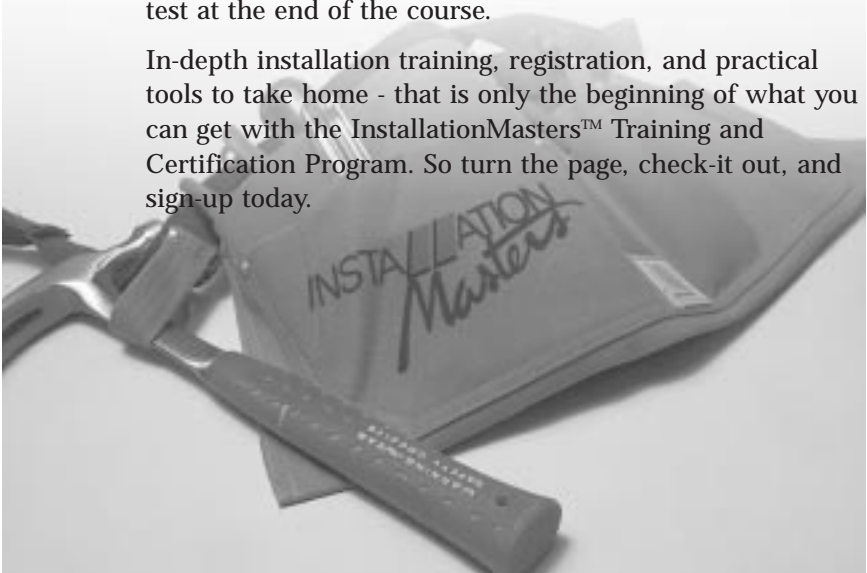

*The InstallationMasters™ Training and Certification Program is owned and managed by the InstallationMasters™ Institute. Architectural Testing, Inc. is licensed by the InstallationMasters™ Institute to administer the program.*

INSTA//ATION™  
Masters



# TABLE OF CONTENTS

<b>InstallationMasters™ Training and Certification Program . . . . .</b>	<b>4</b>
Program Objectives . . . . .	4
Advisory Committee . . . . .	4
Development of the Certification Examination . . . . .	5
<b>Training and Certification Program Information . . .</b>	<b>6</b>
How Do I Participate? . . . . .	6
<i>Trainer</i> . . . . .	6
<i>Installer</i> . . . . .	7
Certification Candidate . . . . .	7
Non-Certification Participant . . . . .	7
Trainee . . . . .	8
What Does the Training Offer? . . . . .	8
Who Will Benefit From the Training? . . . . .	8
How Do I Register? . . . . .	9
<i>Trainer</i> . . . . .	9
<i>Certification Candidate</i> . . . . .	9
<i>Non-Certification Participant</i> . . . . .	11
<i>Trainee</i> . . . . .	11
<b>Test Information . . . . .</b>	<b>12</b>
Taking the Test . . . . .	12
<i>Trainer</i> . . . . .	12
<i>Certification Candidate</i> . . . . .	12
What Does Passing the Test Mean? . . . . .	13
<i>Trainer</i> . . . . .	13
<i>Certification Candidate</i> . . . . .	13
<i>Trainee</i> . . . . .	13



<b>Results of the Test</b> . . . . .	<b>14</b>
<b>Failing the Test</b> . . . . .	<b>14</b>
Trainer . . . . .	14
Certification Candidate . . . . .	14
Trainee. . . . .	14
<b>Re-Testing</b> . . . . .	<b>15</b>
Trainer . . . . .	15
Certification Candidate . . . . .	15
Trainee. . . . .	15
<b>Re-Taking the Class.</b> . . . . .	<b>15</b>
Trainer . . . . .	15
Certification Candidate and Trainee . . . . .	15
<b>Re-accreditation and Re-Certification</b> . . . . .	<b>16</b>
Accredited Trainer . . . . .	16
Certified Installer . . . . .	16
<b>Other Information</b> . . . . .	<b>17</b>
How to File a Complaint about the Program. . . . .	17
Ordering Additional Training Materials . . . . .	17
Ordering InstallationMasters <sup>™</sup> Apparel . . . . .	17
<b>Sample Test Questions</b> . . . . .	<b>18</b>
<b>The Test Specification</b> . . . . .	<b>19</b>

# InstallationMasters™

## Training and Certification Program

### Program Objectives

- To promote consistent, high quality window and door installations in the Residential/Light Commercial markets, promoting energy efficiency, decreasing installation deficiencies, minimizing product failure and callbacks, and thereby lowering ultimate maintenance cost to the consumer.
- To provide a means for trainers and installers to gain specific training regarding current practices used in their field.
- To provide a means of verification of a trainer or installers' knowledge attained during the training course.
- To provide employers of trainers or installers an additional method of determining a potential employees knowledge.
- To improve the credibility of trainers or practicing installers.
- To identify a pool of knowledgeable trainers or installers available to the construction industry.
- To promote installer safety practices.
- To improve future competency of trainers or installers by providing future re-training.
- To provide consumers with information regarding those who have trained and completed this program.
- To promote an installation training program that can be used by manufacturers and builders, as well as building owners and specifiers.

### Advisory Committee

The InstallationMasters™ Advisory Committee is comprised of a representative group of industry leaders including manufacturers, installers, consultants, and other interested parties. Committee members assist in the development and assessment of the policies and procedures of this program. The committee meets periodically to review policies and develop new ideas to make the program more useful.

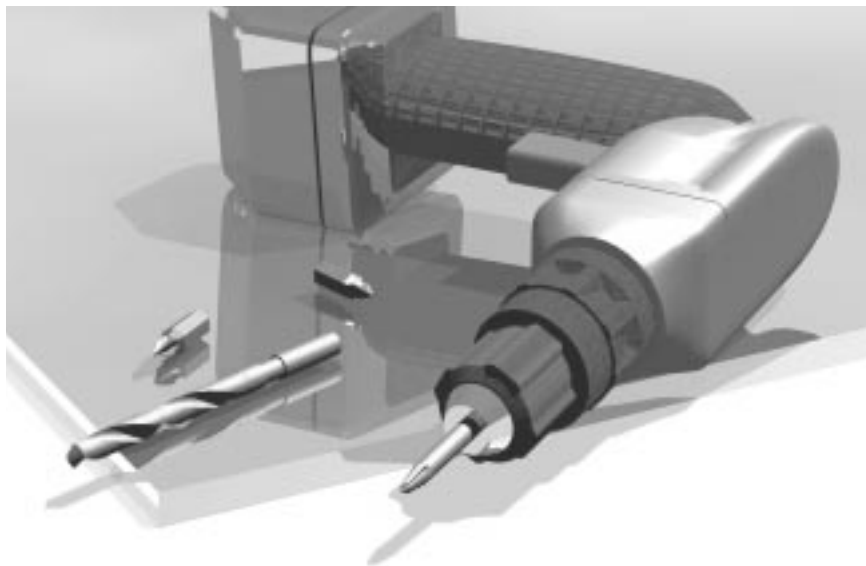

## Development of the Certification Tests

The InstallationMasters™ Training and Certification Tests were developed under the leadership of the InstallationMasters™ Training Advisory Committee and a professional test agency that specializes in the development of professional credentialing tests. The professional guidance assures the fenestration industry that InstallationMasters™ adheres to the highest standards of training and test development.

***Note:** The training and certification requirements of this program have been developed to enhance professional standards within the industry and have no relationship, by design or inference, to local wage schedules, private compensation agreements, or reduction of any management prerogatives regarding promotion or pay.*

# Training and Certification Program Information

## How Do I Participate?

There are two areas of participation, trainer and installer training.

### **Trainer**

Individuals who meet one or more of the following criteria may participate in the trainer program which will allow them to become an InstallationMasters™ Accredited Trainer and sponsor InstallationMasters™ Training and Certification classes for installers upon successful completion of the trainer course:

1. Three or more years of experience as an Instructor, Teacher, or Trainer in the field of building products and technology and three or more years of construction experience. This includes, but is not limited to, Vocational Instructors, Shop Teachers, Armed Services Instructors, and College Professors.
2. Three or more years of experience installing residential and light commercial fenestration products and/or three or more years working as crew leader or field supervisor.
3. Three or more years of experience working for a fenestration manufacturer in engineering, product design, project management, or field services.
4. Three or more years of experience working in a fenestration testing laboratory with related experience in installing/testing products and three or more years working as a team leader, project manager, or supervisor in a fenestration testing laboratory.
5. Three or more years employed with an installation material manufacturer and/or three or more years employed as a fenestration consultant.

## **Installer**

Individuals seeking installer training or certification may register as one of the following:

### **Certification Candidate**

Certification candidates are individuals who practice in the construction field, are involved in product installation, are seeking certification through this program, and wish to take the InstallationMasters™ Test. Certification candidates with one year or more of installation experience may participate in installer training and certification classes sponsored by an InstallationMasters™ Accredited Trainer.

Certification candidates who meet one or more of the following criteria and do not wish to participate in a training class may participate in the self-study program where they study independently in lieu of classroom training and then take the test:

1. High school diploma or high school equivalent exam and six or more years experience installing windows and doors.
2. AA Degree or trade school certificate and three or more years experience installing windows and doors.
3. BS Degree or higher in Construction Engineering and two or more years experience installing windows and doors.

### **Non-Certification Participant**

Non-certification participants are individuals who are interested in participating in installer training and certification classes sponsored by an InstallationMasters™ Accredited Trainer for knowledge purposes only. They are typically not involved in product installation, are not seeking certification, and do not wish to take the exam. There are no experience or educational pre-requisites required for non-certification participants.

## **Trainee**

Trainees are individuals who are seeking certification, but have less than one year of installation experience. Trainees will participate in installer training and certification classes sponsored by an InstallationMasters™ Accredited Trainer, and take the InstallationMasters™ test. When they achieve the required installation experience they may become certified if they have passed the test.

## **What Does the Training Offer?**

The InstallationMasters™ Training and Certification Program offers information on industry accepted installation practices and other critical information related to the window and exterior glass door installation business. The program offers training in subject matter even experienced individuals might not otherwise obtain.

Individuals will be exposed to numerous topics related to both new construction and replacement installation of residential and light commercial windows and exterior glass doors. The training focuses on understanding windows and doors as well as current installation practices of these products. The training will provide individuals the opportunity to gain the knowledge necessary to perform their work in a satisfactory manner. Training involves subjects that range from initial site inspection to final cleaning and maintenance of installed product.

## **Who Will Benefit From the Training?**

The InstallationMasters™ Training and Certification Program is offered on a voluntary basis and is strongly recommended for both seasoned veterans and those with limited experience. Properly trained installers typically have fewer call-backs and complaints resulting in satisfied customers and higher profits.

## How Do I Register?

### **Trainer**

Individuals seeking InstallationMasters™ Trainer Accreditation should contact Architectural Testing, Inc. at 717-764-7700 or [installationmasters@archtest.com](mailto:installationmasters@archtest.com) for more information.

### **Certification Candidate**

Individuals participating in an InstallationMasters™ Training and Certification Program class sponsored by an InstallationMasters™ Accredited Trainer must fill-out and submit the InstallationMasters™ Registration Form included with this handbook along with the following registration materials to the class sponsor:

1. Letter from a past or present employer or other verifiable evidence demonstrating the number of years of installation experience (must be one or more years).
2. Original color or black and white photo of yourself (clear head shot), which can be purchased at locations where passport-type photos are sold.
3. A copy of a signed photo identification card (drivers license, identification card or other identification form).
4. Full non-refundable registration fees made payable to the class sponsor.

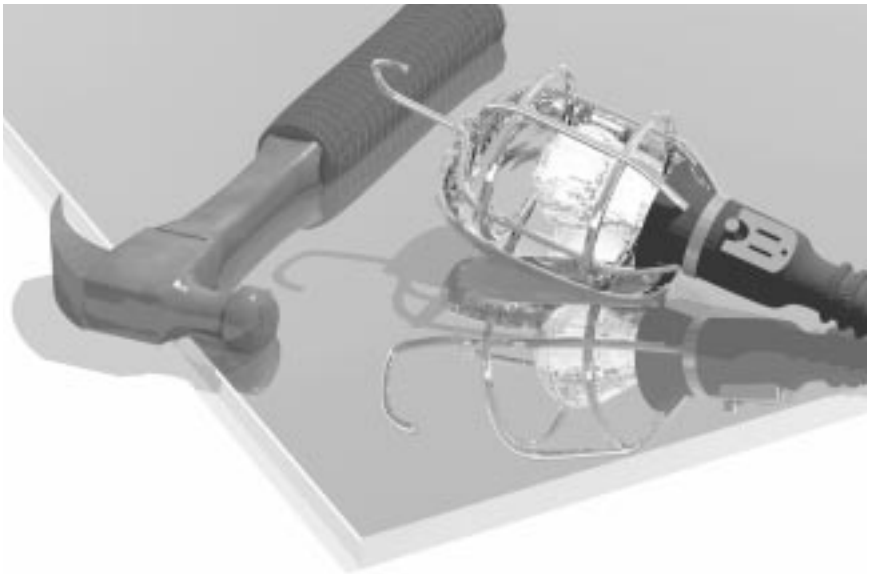

Individuals participating as self-study participants in the InstallationMasters™ Training and Certification Program must fill-out and submit the InstallationMasters™ Self-Study Registration Form included with this handbook along with the following registration materials and applicable fees to Architectural Testing, Inc.:

1. Letter from a past or present employer or other verifiable evidence demonstrating the number of years of installation experience (must be two or more years).
2. Proof of education by copies of college (or trade school) transcript and/or high school diploma.

**Note:** Please see the "Certification Candidate (Self-Study) Section on page 7 regarding installation and education requirements.

3. Original color or black and white photo of yourself (clear head shot), which can be purchased at locations where passport-type photos are sold.
4. A copy of a signed photo identification card (drivers license, identification card or other identification form).
5. Full non-refundable registration fees made payable to Architectural Testing, Inc.

After registration materials are received and approved, self-study participants will receive a confirmation letter, InstallationMasters™ Training Manual, video, test voucher, and Proctor Information/Verification form. After the training materials are received and individuals are ready to take their test, they must contact an individual qualified to proctor tests. Proctors may be found at libraries and community colleges. It is the individual's responsibility to schedule an appointment with the proctor and submit the Proctor Information/Verification form to Architectural Testing, Inc. Architectural Testing, Inc. will contact the proctor to verify qualifications and follow-up with the procedures and test materials they will need to proctor the test.

## **Non-Certification Participant**

Individuals participating in an InstallationMasters™ Training and Certification Program class sponsored by an Accredited Trainer must fill-out and submit the InstallationMasters™ Registration Form included with this handbook along with the following registration materials to the class sponsor:

1. Full non-refundable registration fee made payable to the class sponsor.

## **Trainee**

Individuals participating in an InstallationMasters™ Training and Certification Program class sponsored by an Accredited Trainer must fill-out and submit the InstallationMasters™ Registration Form included with this handbook along with the following registration materials to the class sponsor:

1. Letter from a past or present employer or other verifiable evidence demonstrating the amount of installation experience if applicable.
2. Original color or black and white photo of yourself (clear head shot), which can be purchased at locations where passport-type photos are sold.
3. A copy of a signed photo identification card (drivers license, identification card, or other identification form).
4. Full non-refundable registration fees made payable to the class sponsor.

The class sponsor will submit all appropriate registration materials and fees to Architectural Testing, Inc. for processing.

# Test Information

## Taking the Test

All trainers who wish to gain accreditation, and trainees and certification candidates who wish to gain certification through the InstallationMasters™ Training and Certification Program must take the test.

### **Trainer**

Trainer candidates will take the test at the end of the class they attend which will be administered by an Architectural Testing, Inc. Accredited Trainer. The test will consist of multiple choice questions. No teaching aides or reference materials of any kind will be permitted during the test.

### **Certification Candidate**

Certification candidates and trainees will take the test at the end of the class they attend, which will be administered by the Accredited Trainer teaching the class. The test will consist of multiple choice questions. Candidates will have a limited amount of time to complete the test. No teaching aids or reference materials of any kind will be permitted during the test.

Certification candidates participating in the self-study program will take the test on the date scheduled with the proctor as coordinated with Architectural Testing, Inc. Individuals must present their test voucher provided by Architectural Testing, Inc. to the proctor, along with two forms of identification, when they arrive. One must be a photo identification card and both must have their signature. Candidates will have a limited amount of time to complete the test. No test aids or reference materials of any kind will be permitted during the test.

## What Does Passing the Test Mean?

By passing the test, accredited trainers, trainees, and certification candidates demonstrate the knowledge required to complete the course in good standing.

### **Trainer**

Candidates who pass the Trainer test with a 90% or above and satisfactorily demonstrate their ability to train will become an InstallationMasters™ Accredited Trainer and receive a certificate of accreditation. Trainers who also meet the certification candidate criteria and submit the appropriate registration materials may also become a Certified InstallationMasters™ Installer. In addition to their trainer certificate, they will also receive a wallet-size InstallationMasters™ Certification Identification Card, including their picture, showing the certification level attained.

### **Certification Candidate**

Certification candidates who pass the test with a 70% or above will become a Certified InstallationMasters™ Installer and will receive a certificate of completion and a wallet-size InstallationMasters™ Certification Identification Card, including their picture, showing the certification level attained.

### **Trainee**

All trainees taking the test will receive a certificate of completion and a wallet-size InstallationMasters™ Trainee Identification Card, including their picture, showing the training level attained and the construction type regardless of whether they pass or fail the exam. If the trainee passes the exam, they may become eligible for certification after 12 months installation experience is achieved and verified. They will then receive a certificate of completion and an InstallationMasters™ Certification Identification Card valid for the remainder of the four year period following the date of their training. If the trainee fails the initial test and they desire to continue with the process, they are required to re-take the test and pay related fees after 12 months installation experience is achieved. Upon passing the test, the trainee will receive an InstallationMasters™ Certification Identification Card valid for the remainder of the four year period following the date of their training.

## Results of the Test

All tests will be submitted to Architectural Testing, Inc. for scanning and scoring. After scoring the tests, Architectural Testing, Inc. will send the results within 30 days to the candidates and trainer, where applicable.

## Failing the Test

### **Trainer**

Trainer candidates who do not pass the test will be given the opportunity to re-test at a later date.

### **Certification Candidate**

Certification candidates who do not pass the test will receive notification along with instructions on how to re-test. Exam fees will be charged for re-testing.

### **Trainee**

If the trainee fails the initial test, they are eligible to re-take the test and pay exam fees after 12 months installation experience is achieved. Upon passing the test, the trainee will receive an InstallationMasters™ Certification Identification Card valid for the remainder of the four year period following the date of their training.

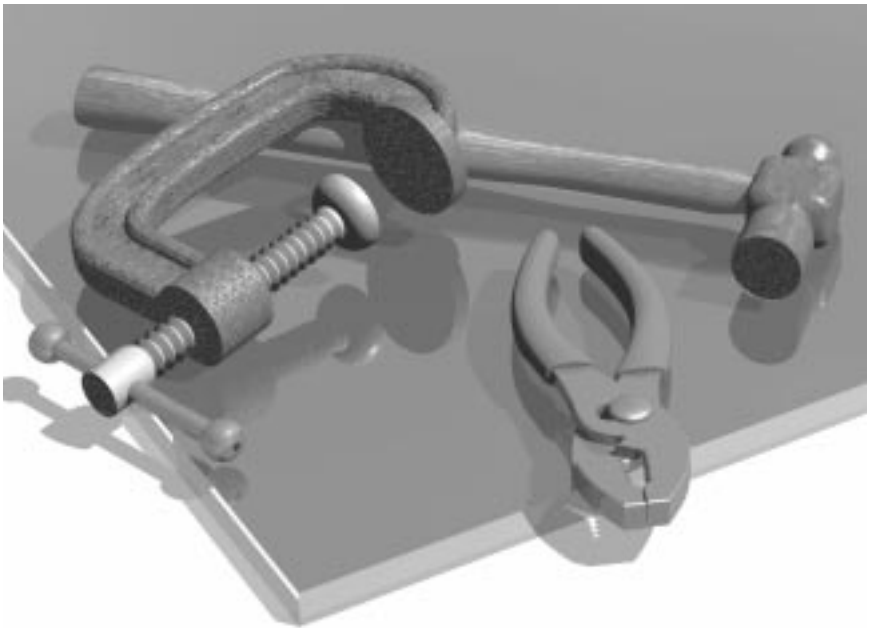

# Re-Testing

## **Trainer**

One re-test will be offered. Candidates who fail to pass the test on the second attempt and desire to continue with the process will be required to re-take the Trainer class and pay all appropriate fees.

## **Certification Candidate**

Certification candidates will be required to pay the full test fee for re-tests. A maximum of two re-tests will be allowed.

Candidates who fail to pass the test on the second attempt and desire to continue with the process will be required to re-take the InstallationMasters™ Training and Certification class and pay all appropriate fees. Self-study candidates who fail to pass the test after three attempts will be required to participate in an InstallationMasters™ Training and Certification class and pay all appropriate fees in order to continue with the process.

## **Trainee**

Trainee candidates will be required to pay the full test fee for re-tests. A maximum of two re-tests will be allowed. Trainees who fail to pass the test on the second attempt and desire to continue with the process will be required to re-take the InstallationMasters™ Training and Certification class and pay all appropriate fees.

# Re-Taking the Class

## **Trainer**

Candidates will be required to contact Architectural Testing, Inc. to re-register for another Trainer class.

## **Certification Candidate and Trainee**

Candidates will be required to contact the class sponsor or Architectural Testing, Inc. to re-register into the next available class in their area.

## Re-Accreditation and Re-Certification

### Accredited Trainer

Trainer Accreditation is valid for one year. Accredited trainers are required to teach a minimum of two InstallationMasters™ classes per year and pay the associated re-accreditation fee in order to maintain their accreditation. Prior to the date that the trainer's accreditation expires, Architectural Testing, Inc. will send notification with re-accreditation instructions and a re-accreditation registration form.

### Certified Installer

InstallationMasters™ Certified Installer certification is valid for a period of four years. Certified installers are required to take a Re-Certification test, which can either be taken on-line or by having a hard copy sent to them via UPS. Ninety days prior to the date of expiration, Architectural Testing, Inc. will send notification to the installers with re-certification instructions and a re-certification registration form. A nominal fee is charged for the re-certification process.



## Other Information

### **How to File a Complaint about the Program**

Anyone who has a problem or concern about the program is urged to notify Architectural Testing, Inc. in writing via Certified Mail at the address provided.

Any complaints that cannot be resolved by Architectural Testing, Inc. will be submitted to the InstallationMasters™ Institute for consideration. The InstallationMasters™ Institute will review and act on the complaint and respond in writing through Architectural Testing, Inc. The InstallationMasters™ Institute will meet periodically. Complainants will be notified of the next scheduled meeting in the event that they wish to present their complaint in person. After the InstallationMasters™ Institute has met and acted upon the complaint, the candidate will receive a response in writing. To contact Architectural Testing, Inc. regarding complaints about the program, send a certified letter to the following address:

**Architectural Testing, Inc.  
ATTN: InstallationMasters™  
130 Derry Court  
York, Pennsylvania 17402**

**New Zip Code**

**After July 1, 2006**

**17406-8405**

### **Ordering Additional Training Materials**

As a participant, you may order additional copies of the InstallationMasters™ Training Manual and video-training guide. To order contact Architectural Testing, Inc. at (717) 764-7700 or [installationmasters@archtest.com](mailto:installationmasters@archtest.com).

### **Ordering InstallationMasters™ Apparel**

A variety of InstallationMasters™ clothing and accessories is available for purchase. You may order by visiting [www.installationmastersusa.com](http://www.installationmastersusa.com) to view the items available or contact Architectural Testing, Inc. to receive a full-color brochure.

# Sample Test Questions

*(answers on Page 19)*

1. When performing a pre-installation inspection on a replacement project, which of the following is the most important thing that an installer should look for?
  - A. existing water penetration problems
  - B. existing failed insulated glass units
  - C. improperly labeled products in the opening
  - D. poor operation of the existing window
2. Which of the following is a function of the final inspection of the window/door installation?
  - A. testing for tempered glass
  - B. removal of permanent labels
  - C. checking sash operation
  - D. installation of the rough framing
3. When doing replacement work in occupied buildings, the installer should
  - A. only install products when the owners are present
  - B. replace any materials that are not called for in the contract
  - C. use products with heat mirror glass and argon gas
  - D. just remove products that can be finished that day
4. The Fair Housing Act, provides design and construction requirements for public buildings and other buildings that
  - A. consist of four or more dwelling units
  - B. have one or more floors or a basement
  - C. have main entrance and rear exit
  - D. will house persons with a wheelchair
5. Which of the following is the most important reason to perform a final operation check of each window and door?
  - A. to eliminate the need for future maintenance of the product
  - B. to make sure products are working safely for future occupants
  - C. to allow fresh air into the building prior to inspection
  - D. to avoid damage caused by others who may open the product
6. When used as an accessory in replacement openings, the sill angle or a sill extender can be used to
  - A. upgrade the expected water performance of the window
  - B. close off the space between the new and the existing window
  - C. anchor the new sloped sill window into position at the sill
  - D. create a dam that keeps water from getting under the window

# The Test Specification

*(RLC-1) Residential/Light Commercial Window and Door Installer*

The following represents the specification for the RLC-1 examination. This specification is based on results of the Job Analysis Survey taken from a representative group of installers in the industry. Each of the chapters listed below form a percentage of the exam for installers.

- Chapter 1: Introduction (< 1%)
- Chapter 2: Design Considerations (4%)
- Chapter 3: Components and Materials (1%)
- Chapter 4: Types of Windows (< 1%)
- Chapter 5: Types of Exterior Glass Doors (2%)
- Chapter 6: Accessory Items and Special Features (< 1%)
- Chapter 7: Performance Requirements (< 1%)
- Chapter 8: Site Inspections (9%)
- Chapter 9: Codes, Standards, and Specifications (6%)
- Chapter 10: Manufacturer's Installation Instructions (1%)
- Chapter 11: Measuring and Ordering (6%)
- Chapter 12: Inspection and Storage of Windows and Doors (3%)
- Chapter 13: Material Selection and Use (10%)
- Chapter 14: Preparing the Opening for Replacement (14%)
- Chapter 15: Replacement Window Installation (6%)
- Chapter 16: New Construction Installation (14%)
- Chapter 17: Bay, Bow, and Garden Window Installation (4%)
- Chapter 18: Combination Window Installation (3%)
- Chapter 19: Specially Shaped Window Installation (3%)
- Chapter 20: Block Frame Door Installation (3%)
- Chapter 21: Mounting Flange Door Installation (< 1%)
- Chapter 22: Screen Installation (1%)
- Chapter 23: Final Cleaning (4%)
- Chapter 24: Quality Control (3%)
- Chapter 25: Product Maintenance (1%)

## Answers *(from page 18)*

1. A, 2. C, 3. D, 4. A, 5. B, 6. B



INSTA//ATION™  
*Masters*



**Architectural Testing**

Copyright ©2004 InstallationMasters™ Institute  
1827 Walden Office Square, Suite 550, Schaumburg, Illinois 60173  
Web: [www.installationmastersusa.com](http://www.installationmastersusa.com)